

## Specifications

MODEL		GTH-4013 SX	
MEASUREMENTS		Metric	Imperial
Lifting height maximum		13 m	42 ft 8 in
Lifting capacity maximum		4,000 kg	8,817.6 lbs
Lift capacity at maximum height		3,000 kg	6,613 lbs
Lift capacity at maximum reach		1,250 kg	2,755.5 lbs
Forward reach maximum		9.08 m	27 ft 9.5 in
Reach at maximum height		65 cm	2 ft 1.5 in
<b>A</b> Height		2.42 m	7 ft 11.5 in
<b>B</b> Height at steering wheel		1.60 m	5 ft 3 in
<b>C</b> Width		2.33 m	7 ft 7.5 in
<b>D</b> Inside cab width		78 cm	2 ft 7 in
<b>E</b> Track		1.92 m	6 ft 3.5 in
<b>F</b> Wheelbase		2.95 m	9 ft 8 in
<b>G</b> Length at front wheels		4.83 m	15 ft 10 in
<b>H</b> Length at fork-holder plate		6.10 m	20 ft
<b>I</b> Ground clearance		43 cm	1 ft 5 in
<b>L</b> Overall width, stabilisers extended		2.89 m	16 ft 6 in
<b>M1</b> Obstruction angle		38°	38°
<b>M2</b> Departure angle		46°	46°

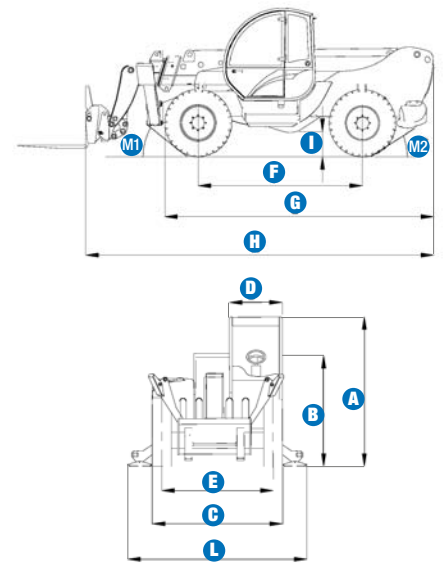

PRODUCTIVITY		
Lifting/lowering speed	11 sec./7 sec	11 sec./7 sec.
Extension/retraction speed	17 sec./18 sec.	17 sec./18 sec.
Inside/outside turning radius	1.14 m/3.79 m	3 ft 9 in/ 12 ft 5 in
Break-out force (with 800 L shovel SAE J 732/80)	5,000 kg	11,022 lbs
Towing capacity at dynamometer	3,940 kg	8,685 lbs
Travel speed (max)	30 km/h	18.6 mph
Fork-holder plate rotation	138°	138°
Chassis levelling on front axle	+/- 6°	+/- 6°
Floating forks	L 1,200 mm Section 120x50mm	L 3 ft 11 in Section 4.5 in x 2 in
Tyres (DIN 70361)	405/70 20" PR14 8 holes wheel rim	

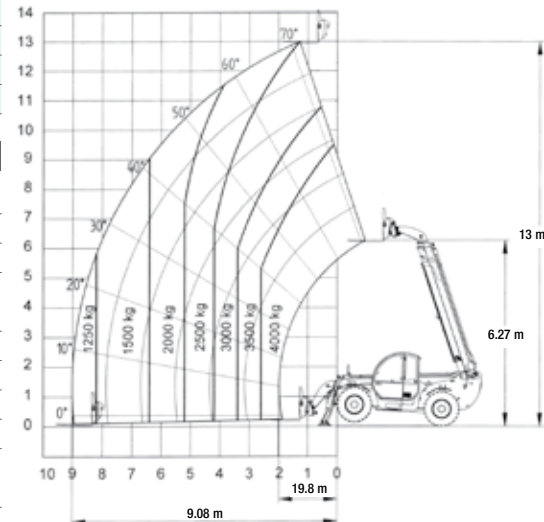

Lift capacity chart (with stabilisers)

POWER		
Engine	Cummins Turbo diesel 99 hp (74 kw)	
Tank capacities		
Petrol	150 L	40 gal
Engine oil	12 L	3 gal
Hydraulic oil	135 L	36 gal
Hydraulic output/pressure	95 L/min-270 bars	20.9 gal./3,916 psi

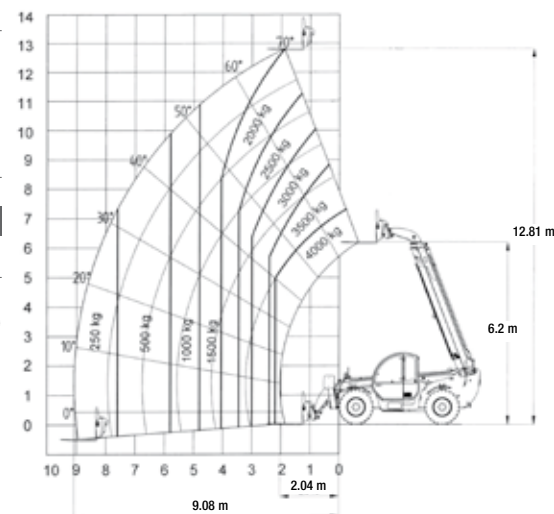

Lift capacity chart (without stabilisers)

EN1459, Annex B

WEIGHT		
Weight*	9,820 kg	21,647 lbs

STANDARDS COMPLIANCE	
Operating cab conforms to ISO3471 (ROPS) and ISO3449 (FOPS)	
Low emission engine conforms to UE 97/68 directives.	
GOST R 50950-96	

\* Weight will vary depending on options and/or country standards

## Features

### STANDARD FEATURES

#### MEASUREMENTS

- 4,000 kg (8,817.6 lb) maximum lift capacity
- 13 m (42 ft 8 in) maximum lift height
- 9.08 m (27 ft 9.5 in) maximum forward reach

#### PRODUCTIVITY

- Four-wheel drive
- Four-wheel steer
- 3 steering modes:
  - front wheel steer
  - crab steer
  - coordinated steer
- Power assisted steering
- Front hydraulic stabilisers
- Mechanical dropbox
- Multifunction proportional 2 x 1 joystick
- Limited slip differential on front axle
- 405/70 20" tyres
- Floating forks
- Adjustable pneumatic seat
- Large diameter steering wheel
- Front windscreen wipers
- Front & rear lights
- Side-mounted engine for easy access to components
- Oil immersed multi-disc brakes on front axle
- Lockable fuel tank
- Longitudinal stability control system with load monitor
- Visible display with coloured LEDs
- Audible alarm
- Automatic lock-out of boom extension and lowering
- Lock-out of stabilisers and chassis levelling with boom raised
- Chassis levelling on front axle +/- 6°
- Automatic lock-out of oscillating rear axle
- Control enable switch

#### POWER

- Cummins turbo diesel 99 hp (74 kW)



### OPTIONS & ACCESSORIES

#### PRODUCTIVITY

- Air conditioning
- Second hydraulic line on boom
- Quick coupling for attachments
- Windshield protection grid
- Wiper on cab roof
- Adjustable spotlight
- 405/70-24" tyres
- Spare wheel
- Foam filled tyres
- 10 ton hydraulic jack and 24 mm wheel nut wrench

#### ATTACHMENT OPTIONS

- Loading shovel 800 L
- 500 L/800 L concrete bucket, manual/hydraulic discharge
- Concrete mixing bucket 500 L with remote control
- Brick-holder basket
- Forks side-shift (+/- 100 mm)
- FEM 3 plate and forks kit
- Fixed hook on plate
- 4 m jib, 900 kg capacity
- 4 m jib with 900 kg capacity hydraulic winch
- 3,000 kg hydraulic winch

### European Offices

#### UK

The Maltings  
Wharf Road  
Grantham NG31 6BH  
UK  
Tel: +44 (0)1476 584333  
Fax: +44 (0)1476 584334

#### France

10, ZA de la Croix St. Mathieu  
28320 Gallardon  
France  
Tel: +33 (0)2 37 26 09 99  
Fax: +33 (0)2 37 26 09 98

#### Germany

Finienweg 3  
28832 Achim/Bremen  
Germany  
Tel: +49 (0)4202 8852-0  
Fax: +49 (0)4202 8852-25

#### Spain

Gaià 31, Pol. Ind. Plà d'en Coll  
08110 Montcada i Reixac  
Barcelona  
Spain  
Tel: +34 93 572 50 90  
Fax: +34 93 572 50 91

#### Scandinavia

Tagenevägen 72  
425 37 Hisings Kärä  
Sweden  
Tel: +46 31 57 51 00  
Fax: +46 31 57 90 20

### Genie United States

18340 NE 76th Street  
P.O. Box 97030  
Redmond, Washington 98073-9730  
USA  
Tel: +1 425 881-1800  
Fax: +1 425 883-3475

**WEB:** [www.genieindustries.com](http://www.genieindustries.com)  
**Email:** [infoeurope@genieind.com](mailto:infoeurope@genieind.com)

### Distributed By: