

Features

EASILY CONFIGURED TO MEET YOUR NEEDS

FORK OPTIONS

- Load platform
- Fork extensions

POWER OPTIONS

- One-speed winch
- Two-speed winch

BASE

- Standard base

CASTER

- Standard casters

OPTIONS & ACCESSORIES

PRODUCTIVITY

- Load platform
- Fork extensions

POWER

- Two-speed winch

STANDARD FEATURES

MEASUREMENTS

ST™-20

- 6.46 m (21 ft 2.5 in) working height
- Up to 363 kg (800 lb) load capacity

ST™-25

- 7.94 m (26 ft .5 in) working height
- Up to 295 kg (650 lb) load capacity

PRODUCTIVITY

- Use as a single unit, or two or more can be used together to support trusses
- Flat black anodized finish is nearly invisible to audience
- Portable and compact design
- Lightweight, durable aluminum construction
- Single-door access
- Easy set-up with no tools required
- Durable steel forks
- Hand winch locks in place when handle is released
- Easy to transport—no bulky base
- Hold-down mechanism secures carriage during transport

POWER

- One-speed winch
- Reversible winch handle for easy storage



Specifications

MODELS	ST™-20		ST™-25	
MEASUREMENTS	Metric	US	Metric	US
A Height - stowed	2.2 m	6 ft 6.75 in	2.2 m	6 ft 6.75 in
B Length - stowed	64 cm	2 ft 1.25 in	64 cm	2 ft 1.25 in
C Width - stowed	56 cm	1 ft 10 in	56 cm	1 ft 10 in
D Load height minimum	15 cm	6 in	15 cm	6 in
E Ground clearance - centre	5 cm	2 in	5 cm	2 in
Working height - forks up	6.46 m	21 ft 2.5 in	7.94 m	26 ft .5 in
- forks down	5.94 m	19 ft 6 in	7.42 m	24 ft 4 in
PRODUCTIVITY				
Load capacity - at 46 cm load centre	363 kg	800 lbs	295 kg	650 lbs
Length - adjustable forks	70 cm	27.5 in	70 cm	27.5 in
Width - adjustable forks	29-76 cm	11.5-30 in	29-76 cm	11.5-30 in
Fork extensions detached each (l/w/d)	76/5/8 cm; 2 kg	30/2/3 in; 4.5 lbs	76/5/8 cm; 2 kg	30/2/3 in; 4.5 lbs
Fork extensions attached each (l/w/d)	64/5/8 cm; 2 kg	25/2/3 in; 4.5 lbs	64/5/8 cm; 2 kg	25/2/3 in; 4.5 lbs
Weight - adjustable forks	24 kg	52.5 lbs	24 kg	52.5 lbs
Outrigger footprint	1.87 x 2.02 m	73.5 x 79.5 in	1.87 x 2.02 m	73.5 x 79.5 in
Casters	standard casters		standard casters	
POWER				
One-speed winch - average cranks	28 cranks/m	8.5 cranks/ft	28 cranks/m	8.5 cranks/ft
WEIGHT*				
	230 kg	507 lbs	252 kg	555 lbs

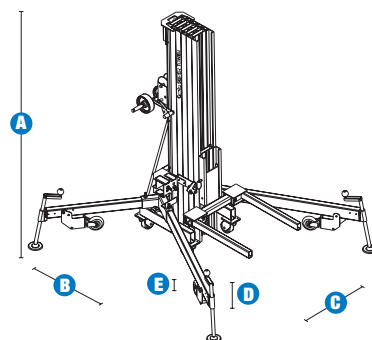

* Weight will vary depending on options and/or country standards.

Genie Europe

The Maltings
Wharf Road
Grantham NG31 6BH
U.K.

Telephone **+44 (0)1476 584333**
Fax +44 (0)1476 584334

Email: infoeurope@genieind.com

Genie United States

18340 NE 76th Street
P.O. Box 97030
Redmond, Washington 98073-9730

Telephone **+1 (425) 881-1800**
Fax +1 (425) 883-3475

Distributed By:

For further information, please contact your local distributor or the Genie Industries sales office listed. Product specifications are subject to change without notice or obligation. The photographs and drawings in this brochure are for illustrative purposes only. Refer to the appropriate Operator's Manual for instructions on the proper use of this equipment. Failure to follow the appropriate Operator's Manual when using our equipment or to otherwise act irresponsibly may result in serious injury or death. Prices and specifications subject to change without notice. The only warranty applicable is the standard written warranty applicable to the particular product and sale. Genie makes no other warranty, expressed or implied. Products and services listed may be trademarks, service marks or trade-names of Terex Corporation and/or its subsidiaries in the USA and other countries and all rights are reserved. Copyright © 2007 Genie Industries, Inc. "Genie" is a Registered Trademark of Genie Industries, Inc. in the USA and many other countries. Genie is a Terex Company.